



SWING DOOR MERCHANDISERS

**GLASS DOOR MERCHANDISERS
REFRIGERATORS
MODEL : FRS-600RP**

FEATURES & BENEFITS

- **Hot gas condensate system** *Only Turbo Air models*
Through Turbo Air's creative innovation, the condensate system surfaces have been specially treated to resist corrosion. This not only increases efficiency without the risk of refrigerant leakage from corrosion, but also prevents the overflow of condensate water.
- **LED advertising panel**
LED lighting offers 5 times longer lasting life than fluorescents and conserves energy as well.
- **LED lighting interior**
Brighter and longer lasting LED lights provide attractive, enhanced illumination compared to fluorescents. It saves energy by producing less heat, while maximizing the visibility in the display area.
- **Double pane glass door with Low-E glass**
Energy saving double pane glass door is equipped with Low-emissivity glass, which reduce outer heat gain and decrease energy consumption. It enhances energy efficiency and minimizes condensation. Lightweight door construction also reduce door maintenance and bushing wear, which in turn facilitates smoother door openings.
- **Efficient refrigeration system**
Turbo Air's glass door refrigerators are designed with oversized and balanced (CFC Free R-134A) refrigeration systems. These include efficient evaporators and condensers for faster cooling and greater efficiency.
- **Adjustable, heavy duty, PE (polyethylene) coated wire shelves**
- **Bottom mount compressor unit**
- **Ergonomically designed door with easy grip handle**
- **Magnetic door gasket**
- **High-density polyurethane insulation**
The entire cabinet structure is foamed-in-place using high density, CFC free polyurethane insulation.
- **Refrigerator holds 0°C ~ 8°C for the best in beverage preservation**



Model	Swing Door	CU./FT.	#of Shelves	HP	AMPS	Crated Weight (lbs.)	L x D* x H (inches)
FRS-600RP	1	22	4	1/4	7.6	243	283/4 x 275/8 x 797/8

SWING DOOR MERCHANDISERS

GLASS DOOR MERCHANDISERS
REFRIGERATORS
Model : FRS-600RP

Model : FRS-600RP

Model	FRS-600RP
Refrigerant	R-134a
COMP (HP)	200g
POWER INPUT(W)	1/5HP
Energy	
AMPS(A)	1.5
Capacity	602
Product Dimension	731
Product Dimension	764
Product Dimension	2105
Weight	104
Stainless steel	EGI (WHITE)
Features	analogue
Max GN Pan depth	
GN Pan	
Door lock	X
Adjustable Shelves	4
LED light	yes
Temperature range	0~8°C
Ambient	
Drainage /	Yes
Temperature	Bar Thermometer
Cooling type	FAN COOLING
Glass Type (Low-e / Heater / How many layer of the glass)	Double Pane Glass Door with Low-E glass

Design and specifications subject to change without notice.
Actual Shipping weight may differ due to extra packing materials for product protection.

- White color cabinet & black color frame on door
- Gravity feed shelf available (optional)
- Price tag channel available (optional)

OPTIONAL ACCESSORIES :

- - Additional PE coated wire shelf: 30278H0600
 - Gravity feed shelf: 30278H0200
 - Price tag channel: P0122K5200 (21"L)

PLAN VIEW

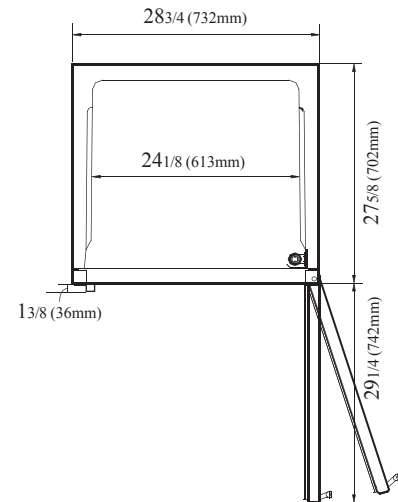

PLAN VIEW

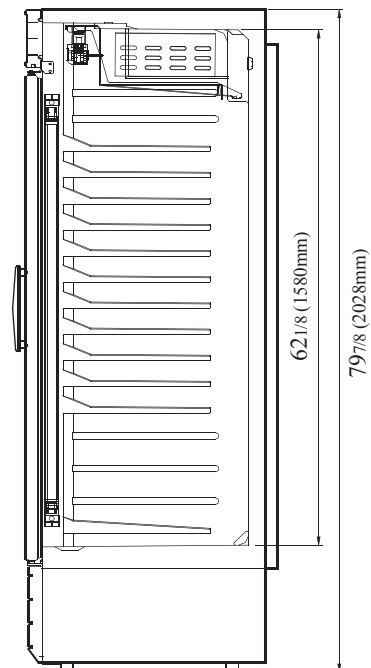

SIDE VIEW

WARRANTY 3 YEARS
PARTS & LABOUR



AUSTRALIA BRANCH

Turbo air

TURBO AIR PTY LTD
www.turboairinc.com.au
1st Floor, Building E
10 Highgate St, Auburn
NSW 2144 Australia
T. 02 9737 9881